

Handguard Installation

Skill Level: Must understand how to perform basic field strip. Please consult a qualified gunsmith if you do not feel comfortable performing the following procedure.

Before you begin, make sure the firearm is unloaded, chamber cleared and made safe.

Installing the Side Mounted Picatinny Rails:

Refer to Figure A

1. There are four possible mounting locations for the side mounted Picatinny rails. Having chosen your mounting locations, remove the slotted rubber mounting hole covers from the side of the handguard using a small flat-head screw driver or similar tool.
2. Slide the provided hex nuts between the heat shield and handguard body.
3. Place the side mount Picatinny rails into the mounting hole slot and secure with the provided hex head screws. **DO NOT OVER TIGHTEN.** Using a small amount of thread-lock compound is recommended to help prevent the hardware from loosening under use.

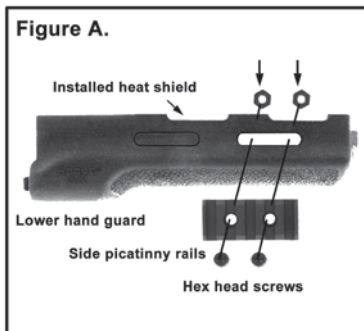

Installing the Bottom Mounted Picatinny Rail:

Refer to Figure B

1. If installing the bottom mounted Picatinny rail, the heat shield must first be removed to expose the mounting holes.
2. Carefully squeeze the sides of the heat shield together, exposing the heat shield retaining tabs. Carefully lift out the heat shield, making sure not to stress the retaining tabs as they may break.
3. Using a small Phillips screw driver or similar tool, poke through the OverMolded® rubber skin covering the three mounting holes.
4. Place the provided Phillips head screws through the mounting holes from the inside of the handguard. Attach the lower Picatinny rail with the provided hex nuts. **DO NOT OVER TIGHTEN.** Using a small amount of thread-lock compound is recommended to help prevent the hardware from loosening under use.
5. Reinstall the heat shield by carefully squeezing the sides of the heat shield together making sure the retaining tabs clear the sides of the handguard body as it is lowered back into place. Make sure the retaining tabs seat into the tab slots in the handguard.

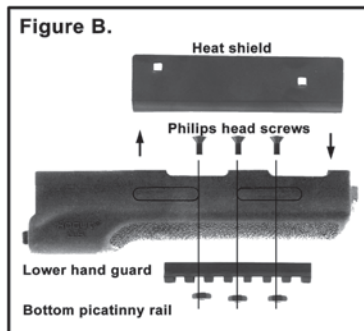

6. Once in place, if the heat shield is loose, insert your fingers into the heat shield and pull the heat shield toward the body of the handguard.

Installing the Monogrip, Upper and Lower Handguards:

Refer to Figures C and D

AK Disassembly / Assembly

1. Remove magazine and cleaning rod if attached.
2. Remove receiver cover, recoil spring assembly and bolt carrier assembly.
3. If included in kit, remove the original grip and replace with the Hogue Monogrip and supplied screw.
4. Remove upper handguard gas cylinder assembly and lower handguard.
5. Install Hogue OverMolded lower handguard. **NOTE:** Due to variation in rifle manufacturing, the front of the Hogue lower handguard may need to be filed shorter in order for the lower handguard band clamp to close.
6. Remove upper handguard from gas cylinder by rotating the gas tube 180 degrees about the handguard. If present, remove metal retaining clip from handguard.

7. If present, place metal retaining clip in the Hogue upper handguard. The Hogue upper handguard has been designed to work with or without the retaining clip.
8. Install the Hogue upper handguard onto the gas tube and rotate back into place.
9. Install the upper handguard gas cylinder assembly.
10. Install the bolt carrier assembly, recoil spring assembly and receiver cover.

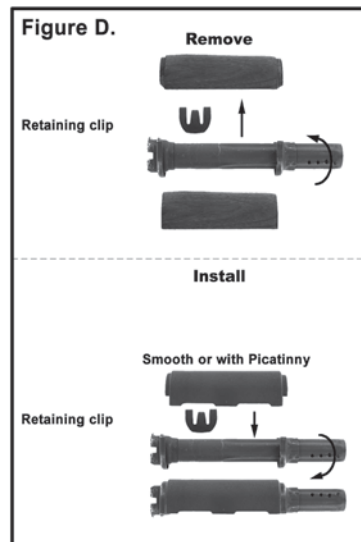
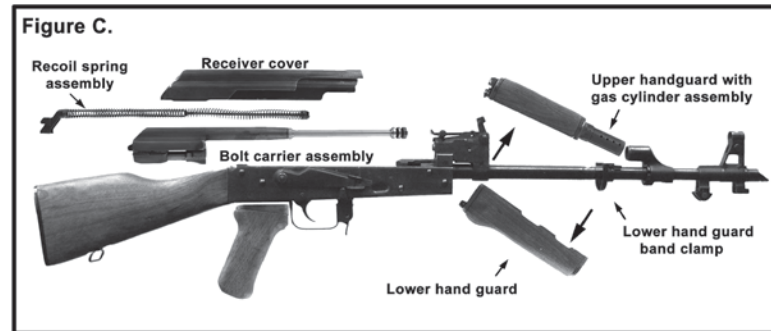

IMPORTANT!

Check all functions of your firearm after installation. Test fire your firearm. This is especially important if firearm is to be used for law enforcement duty.